

**Mammutico®**

# CREATIVE playgrounds

in a playroom,  
in a hotel, in the water,  
and on a picnic



OFFER 2025/2026

[mammutico.com](http://mammutico.com)

# A PLAYGROUND, that fits in your bag

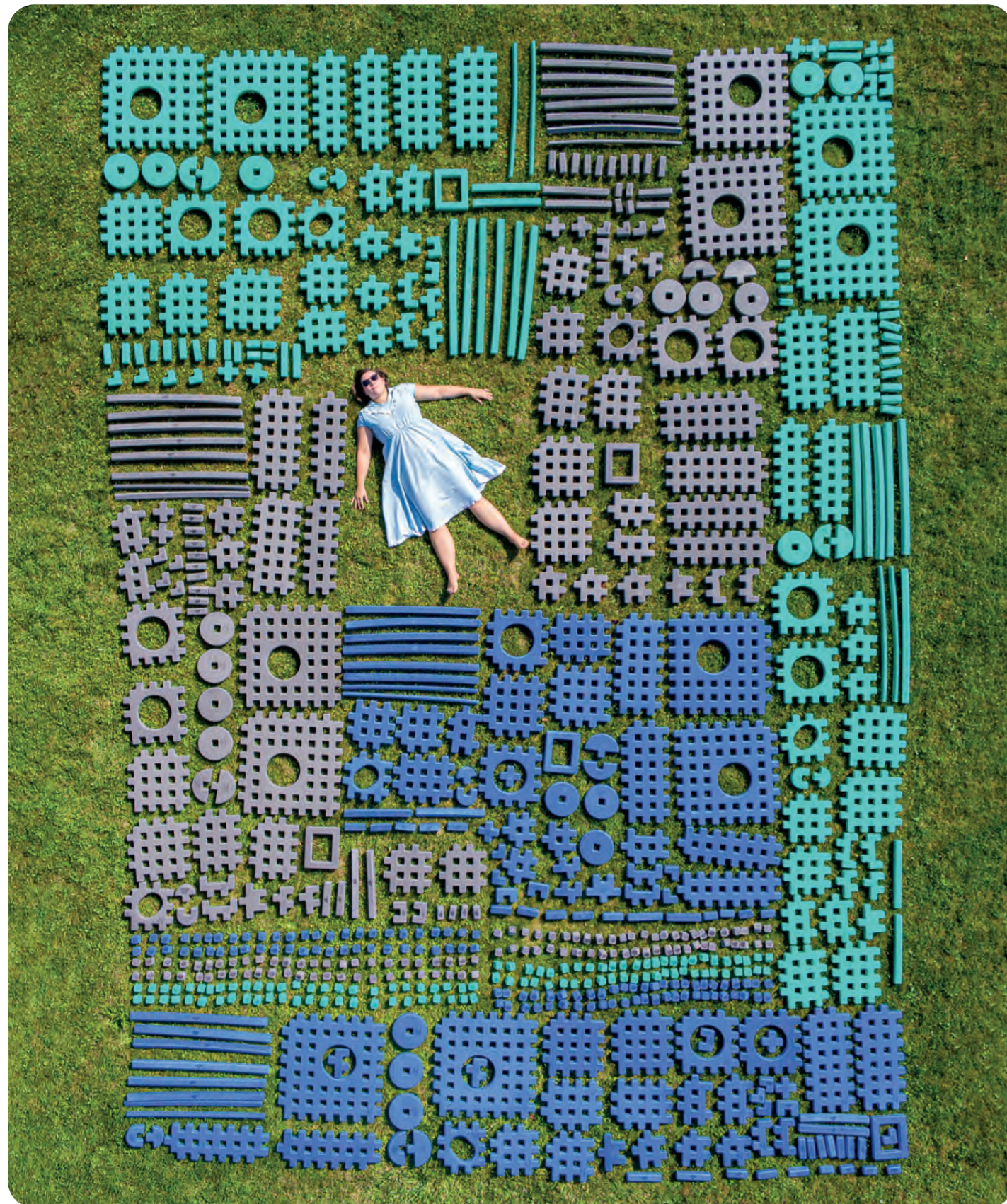

## table of contents

 playground playroom 4	<b>CONNECT</b> line 14
 playground hotel 6	<b>SIMPLE</b> line 16
 playground picnic 8	<b>BALL TRACK</b> line 17
 playground water zone 10	<b>PERFECT</b> line 18
 practical ideas 12	<b>BASIC</b> line 19
 storage 23	<b>SMART</b> line 20
 combining sets 24	<b>SMART</b> wall 22
 information 25	

# The Mammutico® playground is a ready-made concept and a flexible solution that makes the most of your budget



## Aspects that immediately increase the potential of your space – without unnecessary costs, complex changes, or bureaucracy

### Lower investment costs

The Mammutico® playground requires no reconstruction of the space and no costly installation. One solution replaces multiple pieces of equipment, while its mobility makes it suitable for a wide range of situations – without additional expenses.

### Easy maintenance

The components are durable, designed for intensive use, and easy to clean. They require no costly maintenance or complicated care, saving time and money for your facility.

### Quick implementation

The Mammutico® playground requires no permits or lengthy adaptation. This means full functionality immediately after delivery.

### Flexible use of space

The sets are mobile and easy to move. They are suitable for classrooms, common rooms, corridors, playrooms, and outdoor areas. They allow you to make the most of any space.

### Safety during play

Soft, lightweight components minimise the risk of injuries and accidents, with their quality confirmed by international laboratories. This allows children to play freely, while staff and parents enjoy greater peace of mind.

### A playground that grows with children for different age groups

Just one appropriately selected Mammutico® set will provide attractions for the youngest guests. It will also work well during integration games for adults. And why not play with your children? With us, it comes naturally.

playground  
**playroom**



**SUGGESTED PRODUCT LINES:**

**SIMPLE** → p. 16

**SMART** → p. 20



WATCH VIDEO

**BENEFITS FOR PLAYROOMS:**

- 01 More repeat visits and longer play time – without major investments.**  
New building ideas every day keep children coming back for more. This increases the average length of stay and overall customer satisfaction, without the need for costly upgrades.
- 02 Space for different age groups.**  
You can safely organise play for younger and older children at the same time. This makes supervision easier for staff, reduces the risk of collisions and expands the playroom's offering.
- 03 Educational value that sets your offer apart.**  
You can introduce English classes based on the original Mammutico® programme – SIMPLE English. Learning is combined with movement and creative play, creating an activity that other playrooms do not offer. (A detailed course description, recommended sets and a downloadable manual are available on our website.)
- 04 An attraction that never gets old.**  
The elements allow you to build new structures and create surprising scenarios every day. This keeps your offer fresh and eliminates the need for frequent equipment replacement.
- 05 Flexibility in organising events.**  
The space can be easily adapted to the workshop theme, season or age group. Animators can change the room layout in just a few minutes, without additional tools.
- 06 Ready-made group lesson plans.**  
You can introduce educational programmes for preschools and schools that fill weekday schedules and increase the profitability of the playroom.
- 07 Children and adults playing together.**  
You create a space where parents are happy to join in the activities. This builds strong relationships with your customers and increases family loyalty.
- 08 Birthday parties that make your offer stand out.**  
You can organise active, engaging parties based on ready-made scenarios. This simplifies the work of animators and attracts customers looking for new, memorable ways to celebrate.



**CUSTOMER OPINION:**

**Emilia Walendowska** – Marketing Specialist at a playroom  
Airo Space Kids in Warsaw



„We were very pleasantly surprised that parents are eager to play with their children. Thanks to this, the zone has become a unique place for family activities.”



**SUGGESTED PRODUCT LINES:**

**CONNECT** → p. 14

**SIMPLE** → p. 16

**BALL TRACK** → p. 17

**SMART** → p. 20



WATCH VIDEO

**BENEFITS FOR HOTELS:**

- 01 A new attraction that draws families.**  
A dedicated play area influences booking decisions. You increase occupancy, extend family stays and strengthen your position in the family tourism segment.
- 02 Joint activities for children and adults.**  
You offer your guests more than standard entertainment. Playing together builds emotions, turns the hotel into part of family memories and becomes a reason to return.
- 03 A strong marketing advantage.**  
A unique playroom sets your hotel apart from the competition. You gain greater visibility and better reviews in family-friendly hotel rankings.
- 04 A new attraction without construction or permits.**  
You choose a mobile solution that requires no building work, permits or additional infrastructure. The attraction can be launched quickly, without formalities or a long implementation process.
- 05 A year-round attraction in any space.**  
The playground works indoors, by the swimming pool and outdoors. Children play regardless of the weather, while parents enjoy time to relax.
- 06 An attraction that keeps guests coming back.**  
Engaging play at the Mammutico® playground makes children want to stay longer, while parents are more willing to use other hotel services.

- 07 Birthdays and events that make your offer stand out.**  
You can organise family celebrations and active themed events with a real “wow” effect. This boosts package sales and increases recommendations.
- 08 Fun that brings all children together.**  
The space encourages natural interaction, even among shy participants. Families enjoy a calmer stay and parents leave positive reviews.
- 09 Mobility that turns any place into an attraction.**  
The Mammutico® playground can be set up almost anywhere – in the lobby, conference room, restaurant or on the lawn in front of the hotel. Children stay engaged even while parents are waiting at reception, allowing you to fully utilise your available space.

**CUSTOMER OPINION:**

**Karolina Borowska** – Marketing Manager at the Marina Club Hotel in Gietrzwałd



„The Mammutico® playroom with large blocks is an asset that attracts guests because it is something unusual. What’s more, it is a place that brings together both children and entire families.”





**SUGGESTED PRODUCT LINES:**

**SIMPLE** → p. 16

**BALL TRACK** → p. 17

**BENEFITS AT A PICNIC:**

- 01 A universal attraction for any event.**  
The set works perfectly in any location – on grass, a sports field or a market square. It requires no power supply or installation, so it can be used anytime, anywhere.
- 02 Mobility and easy organisation.**  
The elements are easy to transport and can be assembled in just a few minutes. You gain a hassle-free logistics solution with no technical preparation required.
- 03 Fun for children and adults alike.**  
The playground creates a space where entire families can enjoy activities together. Children, parents and grandparents spend time side by side – without phones and with genuine joy.
- 04 A safe centre for physical activity.** Large, soft elements minimise the risk of injury, allowing children to play safely even in large groups.
- 05 A self-sufficient attraction – no stage or electricity required.**  
Children invent their own games, build structures and create stories. No entertainer, sound system or event script is needed.
- 06 Fun that lasts for hours.**  
Endless building possibilities mean children don't lose interest after a few minutes. They return to develop their ideas and continue the constructions they started earlier.
- Positive energy and social media visibility.**  
Active play brings participants together and energises the event. You create a picnic that will be remembered – full of shared emotions and natural interactions.



**EXPERT OPINION:**

Joanna Zaręba – Child and adolescent psychologist



„Mammutico® is an interesting proposition for both younger children and more experienced and demanding teenagers. This type of fun is also an original challenge for adults and a great alternative way to spend free time for the whole family.”



WATCH VIDEO





**SUGGESTED PRODUCT LINES:**

**SIMPLE** → p. 16

**SMART** → p. 20



WATCH VIDEO

**BENEFITS FOR FACILITIES WITH A WATER AREA:**

- 01** **An innovative offer your competitors don't have.**  
A water playground allows you to stand out from other facilities and strengthen brand recognition. It becomes a signature attraction for your venue.
- 02** **Water play scenarios – a whole new dimension of fun.**  
You introduce experiences that cannot be easily replicated. With water as part of the activity, every scenario gains an extra sensory dimension.
- 03** **Learning to swim through play.**  
Children start learning through fun and become familiar with water more quickly. Training feels enjoyable and natural, not like a chore.
- 04** **Birthdays and water workshops that stand out.**  
Birthday parties and family workshops in the water create memorable experiences that guests will remember long after their visit.
- 05** **A new offer for organised groups.**  
You attract schools and preschools looking for more than a standard swimming pool by offering unique, engaging water-based activities.
- 06** **Family fun in the water.**  
Shared activities strengthen relationships, create a positive atmosphere and increase overall comfort during the stay.
- 07** **Social media visibility that promotes itself.**  
The water playground becomes a natural backdrop for photos and videos that parents are happy to share, generating authentic promotion for your facility.



**CUSTOMER OPINION:**



**Artur Moczarski** – President of the „MOŻESZ” Association for Psychoprophylaxis and the Development of Children and young people.

„The enormous interest of children in Mammutico® blocks is simply an unspoken opinion that is worth following when looking for good, safe and creative fun for the youngest.”





# Four practical ideas

for using the Mammutico® playground in your facility

See how a mobile playground can enrich your offer and provide attractions tailored for various occasions



## PLAYROOM

A zone for playing together with parents

Among slides and inflatables, create a space where parents can actively play with their children. Building, planning and experimenting together provide shared fun and meaningful time spent as a family. Such a zone helps your playroom stand out and encourages families to return.



## PICNIC / EVENT

Creative outdoor zone

Mammutico® sets can be moved in front of a hotel, playroom or swimming pool at any time, instantly turning any open space into a creative outdoor playground. It's a perfect solution for picnics, family days and summer events. You don't need to hire additional attractions — simply use what you already have and bring it outdoors.



## HOTEL

Family imagination workshops

Every Saturday, invite entire families to enjoy creative play together. Adults and children build houses, tunnels, robots and spaceships side by side, discovering the joy of creating something as a team. It's more than entertainment — it's a unique way to strengthen relationships and create memories that guests will associate with your hotel.



## POOL

Family swimming challenges

Once a week, invite families to take part in water-based challenges together. Guided by a coach, parents and children build floating tunnels, platforms and bridges, then test them through play. These sessions encourage cooperation and confidence, help children feel comfortable in the water and naturally support learning to swim — all in an atmosphere of laughter and shared adventure.



# CONNECT line



## The best for creating inventions!

**Ready-made teaching aids:**  
35 STEAMS scenarios

**Design:** the largest and most  
impressive elements in the offer

**Dedicated to:** playrooms and learning centres

**Application:** ideal for creative classes  
and educational demonstrations

**Building style:** spectacular, quick  
and simple large-scale construction

**Character:** construction

**Users:** school-age children,  
teenagers, and adults

**Storage:** convenient  
and compact

**Tidying up:** quick to tidy up

**Compatible sets:**  
SIMPLE, BALL TRACK



WATCH VIDEO

## CONNECT GO SET COMPONENTS

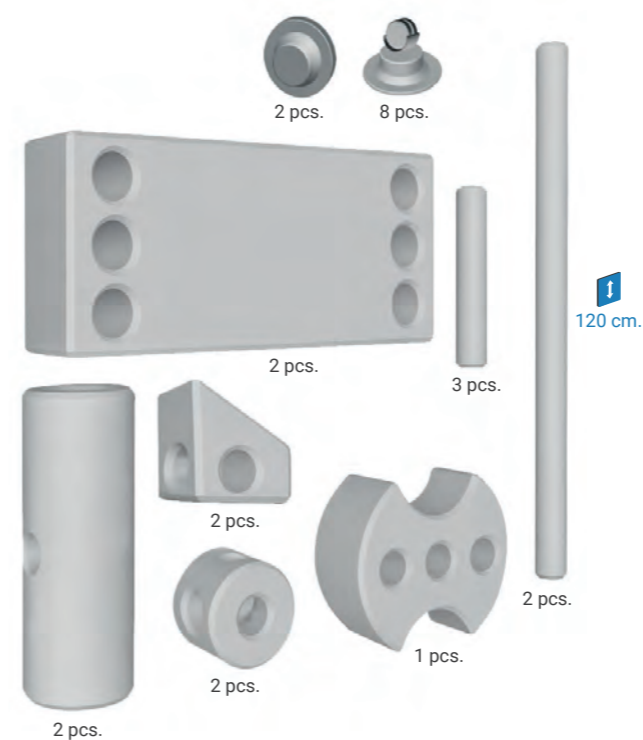

## CONNECT 105 SET COMPONENTS

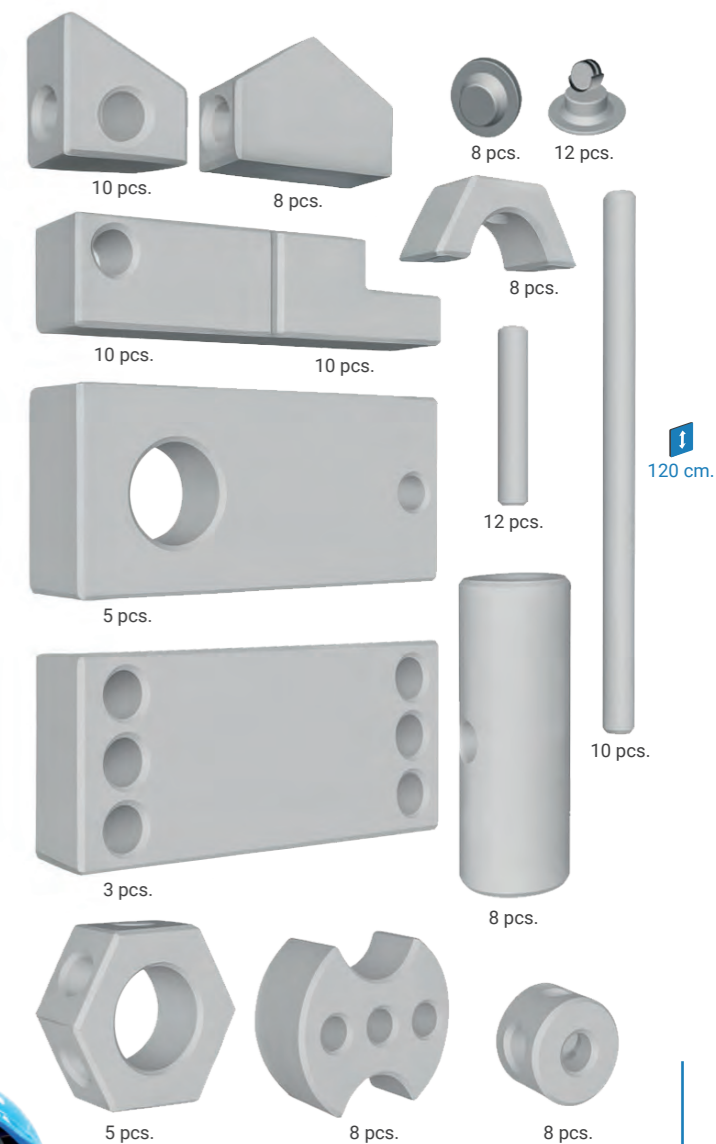

Name	Number of elements in set	Maximum number of colours	Recommended number of users	Minimum play area
CONNECT GO	24 pcs.	grey-blue	4	10 m <sup>2</sup>
CONNECT 105	125 pcs.	2	20	20 m <sup>2</sup>

Available colours:

# SIMPLE

line



## The best for group integration!

**Ready-made teaching aids:**  
20 workshop scenarios

**Design:** large forms, three simple shapes

**Dedicated to:** nurseries and preschools

**Application:** ideal for events and picnics

**Building style:** quick, simple and large construction

**Character:** universal

**Users:** children of all ages

**Storage:** convenient and compact

**Tidying up:** instant tidying

**Compatible sets:**  
BALL TRACK, CONNECT

# BALL TRACK

line



## The best for practising precision!

**Design:** simple elements with chutes and holes for rolling balls

**Dedicated to:** schools and learning centres

**Application:** ideal for experiments with motion and physics

**Building style:** precise and technical track construction

**Character:** technical

**Users:** school-age children and teenagers

**Storage:** convenient and compact

**Tidying up:** quick and easy

**Compatible sets:**  
SIMPLE, CONNECT

### SET COMPONENTS

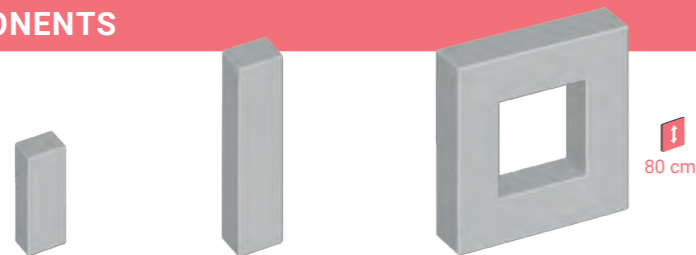

SIMPLE 40	32 pcs.	8 pcs.	0 pcs.
SIMPLE 70	52 pcs.	16 pcs.	2 pcs.
SIMPLE 100	72 pcs.	24 pcs.	4 pcs.
SIMPLE 140	104 pcs.	32 pcs.	4 pcs.

Name	Number of elements in set	Maximum number colours in set	Recommended number users	Minimum play area
SIMPLE 40	40 pcs.	2	5	10 m <sup>2</sup>
SIMPLE 70	70 pcs.	4	15	15 m <sup>2</sup>
SIMPLE 100	100 pcs.	4	20	20 m <sup>2</sup>
SIMPLE 140	140 pcs.	5	30	30 m <sup>2</sup>

Available colours:



WATCH VIDEO

### BALL TRACK SET COMPONENTS

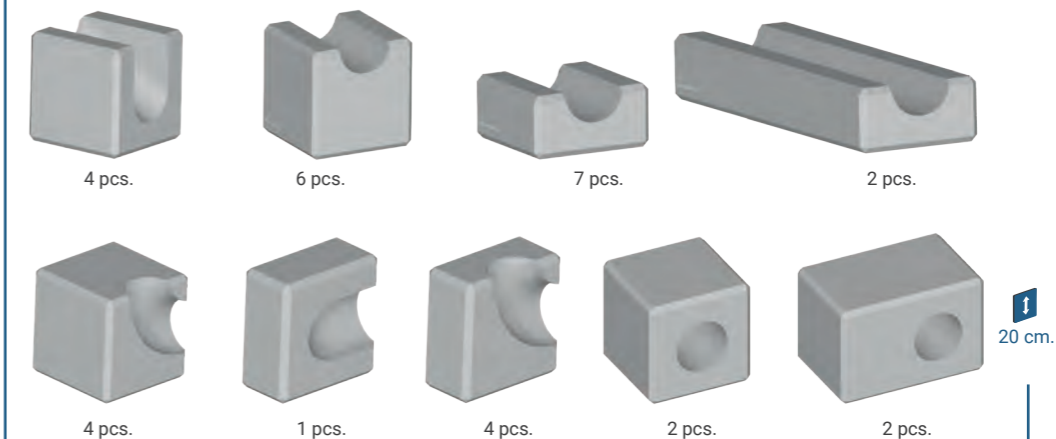

Name	Number and type the set	Maximum number colours in the set	Suggested number users	Minimum play area
KULODROM	32 elements and 20 balls	1	5	10 m <sup>2</sup>

Available colours:



WATCH VIDEO

**PERFECT**  
line



**The best for developing engineering skills!**

Ready-made teaching aids:  
26 detailed instructions

Design: one shape, simple and multifunctional

Dedicated to: daycare centres  
and learning centres

Application: ideal for organised activities

Building style: large  
and advanced construction

Character: construction

Users: school-age children,  
teenagers, and adults

Storage: convenient  
and compact

Tidying up: quick to tidy up

Compatible sets:  
BASIC, SMART

**BASIC**  
line



**A creative addition to the PERFECT line**

Design: one simple shape

Application: expanding the design  
possibilities of the PERFECT set

Storage: convenient  
and compact

Tidying up: quick to tidy up

**SET COMPONENTS**

49 cm.



PERFECT 40	40 pcs.	120 pcs.
PERFECT 80	80 pcs.	240 pcs.
PERFECT 160	160 pcs.	480 pcs.
PERFECT 320	320 pcs.	960 pcs.

Name	Number of elements in set	Maximum number colours in set	Recommended number users	Minimum play area
PERFECT 40	40 pcs.	1	2	5 m <sup>2</sup>
PERFECT 80	80 pcs.	2	4	10 m <sup>2</sup>
PERFECT 160	160 pcs.	4	10	15 m <sup>2</sup>
PERFECT 320	320 pcs.	4	20	20 m <sup>2</sup>

Available colours:



WATCH VIDEO

**SET COMPONENTS**

20 cm.



BASIC 20	20 pcs.
BASIC 50	50 pcs.
BASIC 100	100 pcs.
BASIC 300	300 pcs.

Name	Number of elements in set	Maximum number colours in set	Recommended number users
BASIC 20	20 pcs.	1	2
BASIC 50	50 pcs.	2	4
BASIC 100	100 pcs.	3	10
BASIC 300	300 pcs.	4	20

Available colours:



**SMART**  
line



**The best for STEAMS education!**

**Ready-made teaching aids:**  
20 workshop scenarios, 35 STEAMS scenarios

**Design:** various shapes with distinctive connections

**Dedicated to:** preschools and schools

**Application:** ideal for organised classes

**Building style:** tall and advanced structures

**Character:** construction

**Users:** preschool and school children

**Storage:** recommended bags or containers

**Tidying up:** more items to tidy up

**Compatible sets:** PERFECT, BASIC

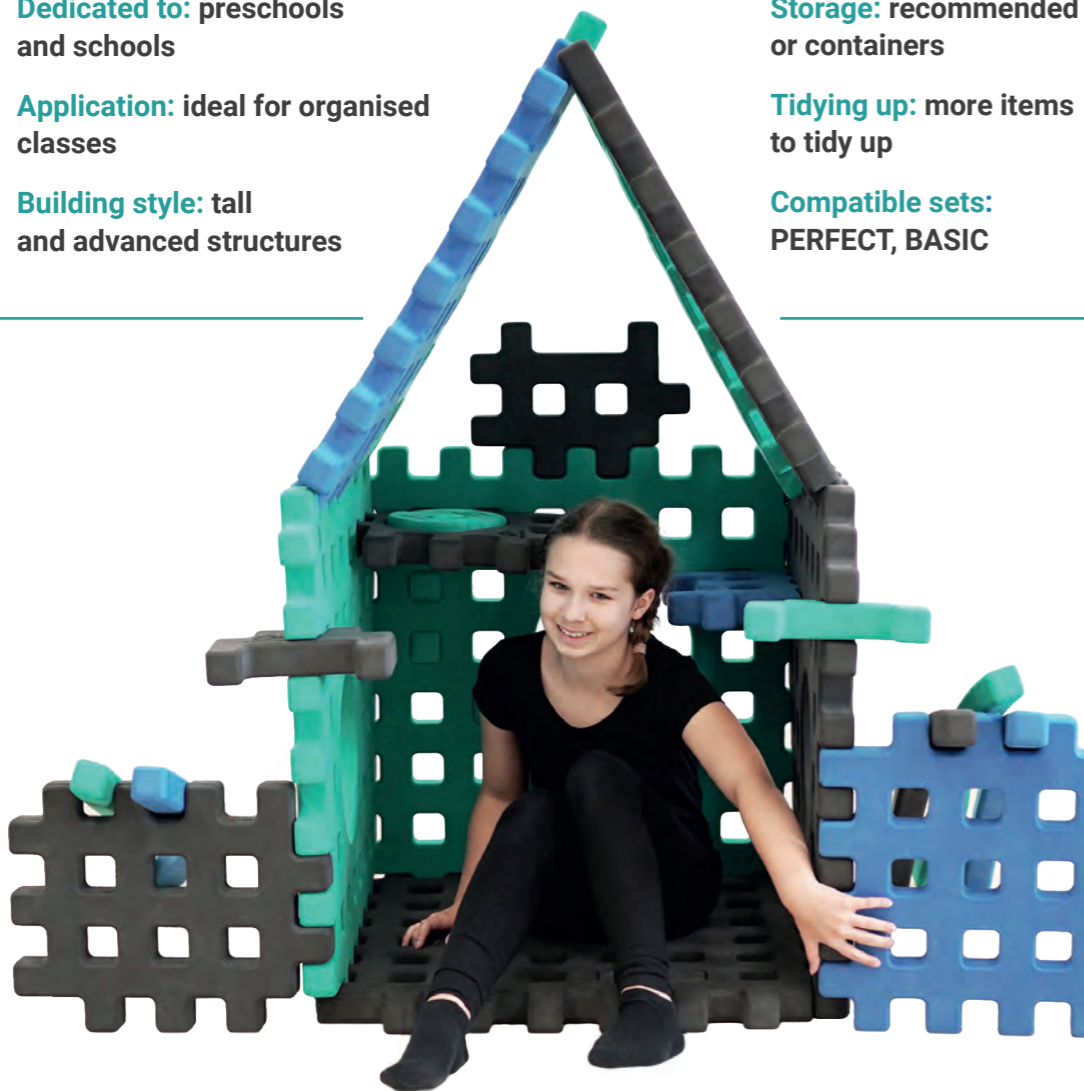

WATCH VIDEO:  
playing with blocks



WATCH VIDEO:  
set features

**SMART 115 SET COMPONENTS – WALK IN THE CLOUDS**

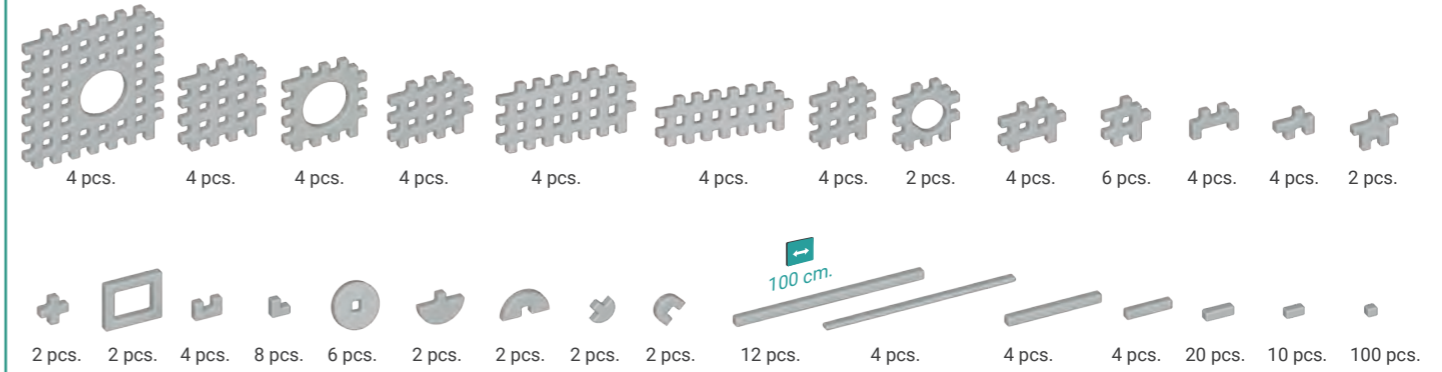

**SMART 230 SET COMPONENTS – THE GREAT EXPEDITION**

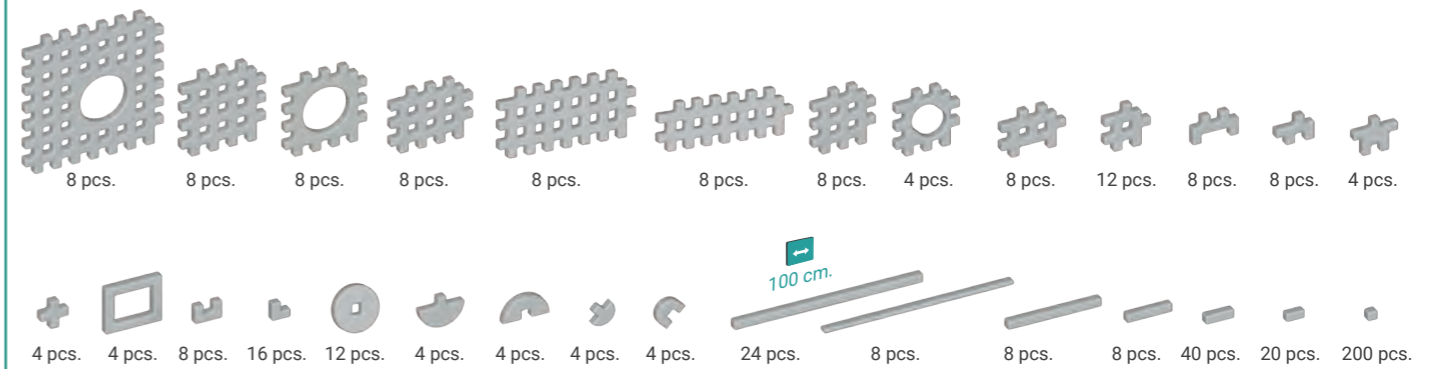

**SMART 345 SET COMPONENTS – JOURNEY TO THE STARS**

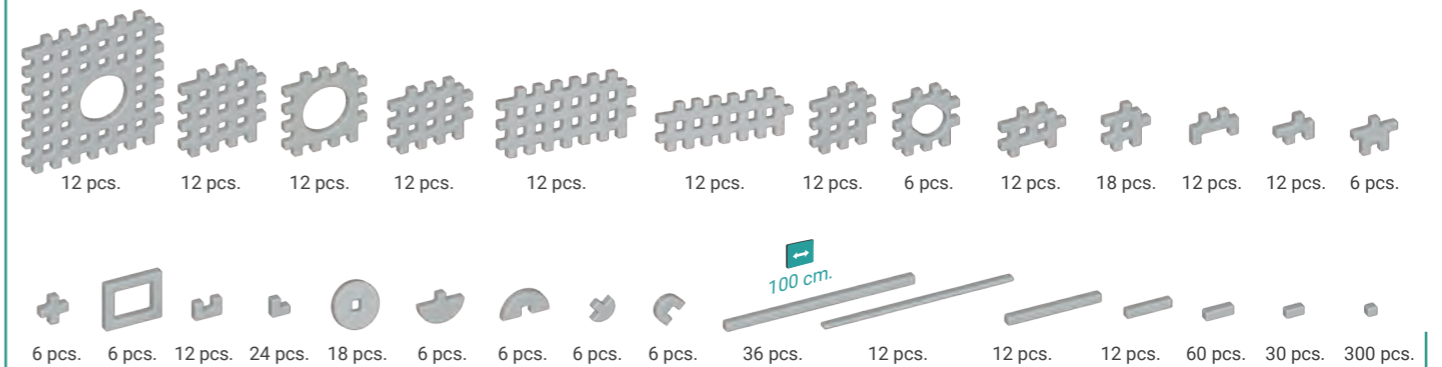

Name	Number of elements in set*	Maximum number colours in set	Recommended number users	Minimum play area
SMART 115 „Walk in the Clouds”	130 and 100 Smart qubes	2	10	15 m <sup>2</sup>
SMART 230 „The Great Expedition”	260 and 200 Smart qubes	4	20	20 m <sup>2</sup>
SMART 345 „Journey to the Stars”	390 and 300 Smart qubes	5	30	30 m <sup>2</sup>

Available colours:

## SMART wall



### Add-on to all sets from the SMART line

#### OPENS UP NEW POSSIBILITIES FOR PLAY AND CONSTRUCTION

**Stable and safe** → allows even the youngest children to play,

**Universal** → you can easily create a multi-storey house, an exciting base or a shop display with shelves,

**Functional** → SMART wafers can be attached to the wall, which strengthens and expands the structure,

**Flexible** → it allows more children to play together than standard sets, making it an ideal solution for nurseries and shared spaces,

**Educational** → symmetrical holes allow for games that introduce children to the world of coding, developing logical thinking.

Made of 18 mm thick waterproof plywood, it works well both indoors and outdoors (the material is weather-resistant). Its solid construction ensures durability and freedom for years of use.

#### THE WALL IS AVAILABLE IN TWO VERSIONS:

**Mobile** → consists of 3 elements that can be arranged in four different configurations

**Fixed** → mounted on the wall, with appropriate elements included in the set, enabling stable mounting and easy interlacing of elements.

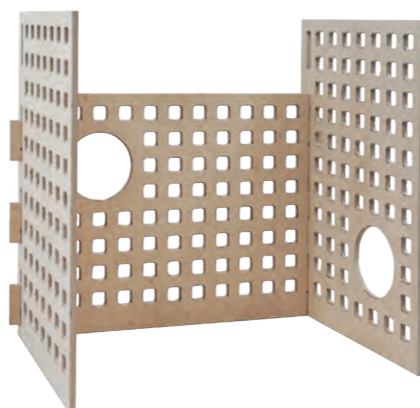

WATCH VIDEO

## Storage



### A practical way to organise your space

#### BAGS:

Each Mammutico set is available with dedicated storage bags in various sizes:

1. Tailored to the number and type of items,
2. Weatherproof, can be stored outdoors,
3. Made of durable, abrasion-resistant material,
4. Equipped with reinforced handles and sturdy seams, ensuring comfortable carrying even for the largest sets,
5. Designed for quick packing and unpacking – especially important in everyday use in nurseries, schools and during events.



WATCH VIDEO:  
See the bags in action



Check out the list of bags and their capacities

#### MAMMUTICO STORAGE:

A practical solution that allows you to store large sets outdoors. Thanks to it, lack of space for a creative playground is no longer a problem.

1. Holds up to 8 XXL bags,
2. Material: galvanised sheet metal panels connected with steel profiles,
3. Can be locked with a padlock,
4. External dimensions at the base: 267x181 cm,
5. No maintenance required or building permit.



Check the parameters and functions of the storage compartment



Name	Number of elements	Dimensions	Thickness
Mobile wall	3 pcs.	2 pcs.: 1176 × 776 mm 1 pcs.: 1209 × 735 mm	18 mm
Fixed wall	3 pcs.	2 pcs.: 1225 × 809 mm 1 pcs.: 1225 × 784 mm	18 mm

## Combine sets and unlock new potential

Combining sets from different lines gives you additional advantages!

It allows you to create even more diverse structures, enriches play and opens up space for new educational projects.



# At Mammutico® we focus on safety and quality!

One of the most important aspects of play is safety. Mammutico® foam blocks are certified with a declaration of conformity, confirming that they are safe for children. They are also extremely lightweight, so even the smallest children can carry them.

The blocks are made of Mammutico Foam™, tested by Polish and international laboratories. They hold all required certifications and comply with Polish and European safety standards!<sup>1</sup>

## Compatible elements

All Mammutico® lines form a coherent system, with shapes and dimensions designed to complement each other and allow the construction of a wide variety of structures. This flexibility lets each child develop at their own pace, choosing the forms that best suit their needs and ideas.



### LINES THAT COMPLEMENT EACH OTHER BEST:

**BALL TRACK + SIMPLE** → large bricks allow you to enrich the ball track with bridges, tunnels or elevations, making the game more dynamic.

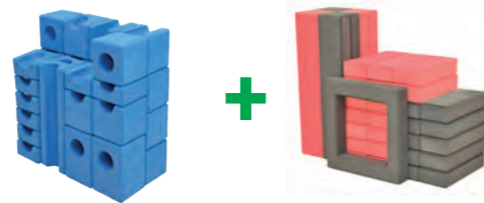

**PERFECT + BASIC** → The width of straight bricks fits perfectly into the openings of PERFECT line elements. The use of BASIC sets allows for better structural stability and the creation of more advanced designs.

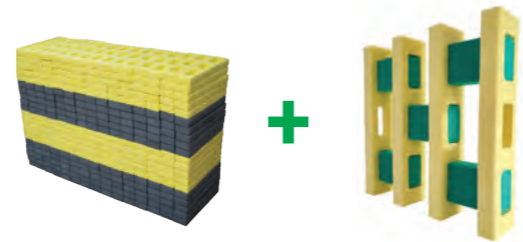

**SMART + PERFECT** → Both sets are structural by design, and the side profiles of the SMART elements are engineered to fit the openings of the PERFECT line. This allows a wide range of shapes to be combined, enabling the creation of stable, more advanced structures that were previously unattainable.

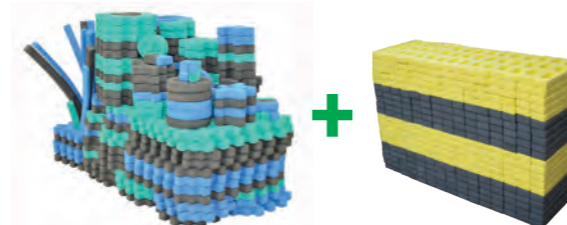

### GRADUAL DEVELOPMENT OF RESOURCES

Mammutico® is an investment that you can expand step by step. You can easily add new lines to your existing set, creating an increasingly rich space for play and learning.

### CONSISTENT AESTHETICS

The colours of the sets have been designed to complement each other well. This means that each new set blends harmoniously with the previous ones, and the whole looks attractive and modern.

### FOAM PROPERTIES:



#### Quick-drying

Wet blocks dry very quickly and can also be wiped with a cloth.



#### Very light

Even the youngest children can join in the fun!



#### Waterproof

The blocks are perfect for playing in the garden or in the pool!



#### Easy to clean

Just wipe the blocks with a damp cloth and you're done! You can also use soapy water or a steam cleaner.



#### Pleasant to the touch

Pleasant, safe and smooth material, no sharp edges.



#### Frost resistant

In winter, the blocks can be stored outside, even in severe frost.



#### Sand resistant

No gaps or recesses where sand could get in.



#### Resistant to UV radiation

It does not fade in sunlight. Its colour always remains the same, regardless of external conditions.



#### Flexible

After bending, it returns to its original shape.

### INSTRUCTIONAL VIDEOS:



Foam properties



Foam durability



Washing the blocks

**3-year warranty for damage resulting from material defects**

**MAMMUTICO® ELEMENTS are extremely durable – an important advantage for your facility's budget.**

<sup>1</sup> Our products comply with the following documents: Directive 2009/48/EC of the European Parliament and of the Council of 18 June 2009 on the safety of toys, as amended. Regulation (EC) No 1907/2006 of the European Parliament and of the Council REACH – Annex XVII, OJ L 396 of 30.12.2006, pp. 1- 794, as amended. PN-EN 71-1+A1:2018-08 – Safety of toys – Part 1: Mechanical and physical properties. PN-EN 71-2:2021-05 – Safety of toys – Part 2: Flammability. PN-EN 71-3+A1:2021-09 – Safety of toys – Part 3: Migration of certain elements.

## How to buy a Mammutico® Playground?

**Online** – Order directly through our online store – the fastest and most convenient way to purchase a Mammutico® playground.

**By email** – Send us an email with your enquiry or order details. After receiving your information and payment, you will receive an order confirmation along with the estimated production and delivery timeline.

**By phone** – Contact us directly – our team is happy to assist you in English.

### Support from our Educational Advisors

If you have any questions or would like to discuss your project in more detail, please visit the [\\_Contact\\_](#) section on the Mammutico website. There you will find the contact details of our Educational Advisors, who will help you choose the right solution, provide expert guidance, and – if needed – arrange a meeting.

### Order Processing Time

Orders placed in December are typically processed in January and February of the following year.



**Mammutico®**

Mammuti Co. Sp. z o.o.

Plac Zgody 6a, 05-820 Piastów

Tel. +48 729 97 37 37

[www.mammutico.com](http://www.mammutico.com)

[info@mammutico.com](mailto:info@mammutico.com)

